

MODERN ENGINEERING WITH CLASSIC STYLING



CLASSIC RADIATOR

When remodeling or updating your home, choose furnishings with the details that compliment your décor. Burnham's Classic Radiator gives you all the comfort of hydronic heat with the elegance of classic styling. Brass valves are available to complete the timeless appearance.



SPECIFICATIONS



The design of the Classic Radiator allows for easy installation in new or existing hydronic systems. Shipped with steel color finish coat ready to install.

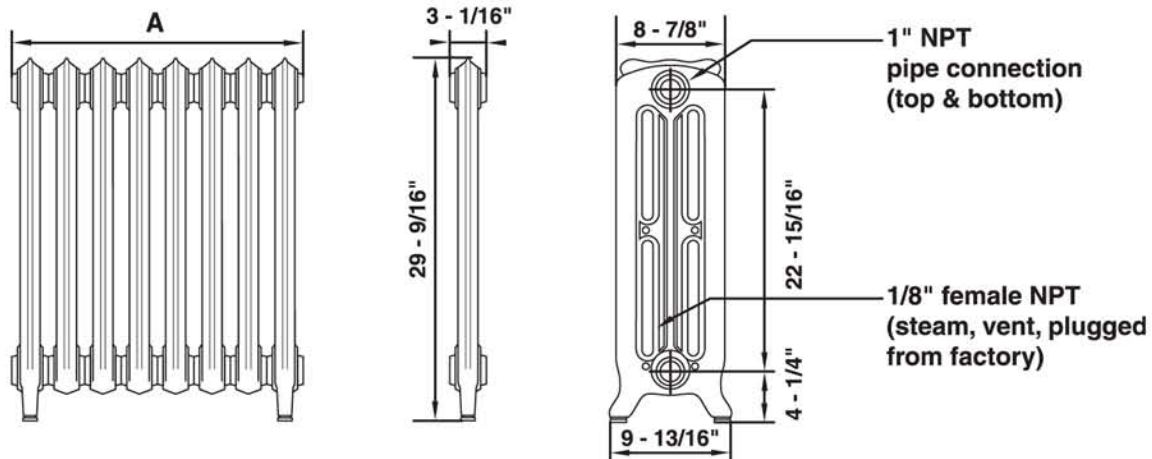

*MODEL NO.	NUMBER OF SECTIONS 3.07" EA.	WIDTH IN INCHES (A)	SQUARE FEET -EDR [©]	WATER OUTPUT BTU/H (180°F AVG. TEMP.)	STEAM OUTPUT BTU/H (215°F AVG. TEMP.)	SHIPPING WEIGHT LBS.
CR-3-CF	3	9.2	9.2	1564	2208	77
CR-5-CF	5	15.4	15.3	2618	3672	129
CR-7-CF	7	21.5	21.4	3655	5136	177
CR-9-CF	9	27.6	27.5	4692	6600	226
CR-5-AF	5-Intermediate	15.4	15.3	2618	3672	129
8074011	End section w/vent	3.1	3.1	524	734	26

- © Heating surface based upon the standard heat emission of 240 BTU per square foot per hour.
- * Stock sizes available for immediate shipment. Assemble 5 section intermediate with 3, 5, 7 or 9 section stock size to make a custom size.
- End section with vent is also used as intermediate leg support for radiators with more than 16 sections.
- Water Content —0.61 gal/section.
- Output based on room temperature of 70°F.
- Maximum recommended pressure 58 psi water, 15 psi steam.
- Special tool required for disassembly/assembly.
- Rating square ft./section = 3.05



3/4" brass isolation and balancing valves acceptable for steam and water systems.

